



SIM - SISTEMA INTEGRADO DE MAUTENÇÃO

PLANO DE MANUTENÇÃO



Específico para carroceria
Junto com plano C ou D

execução



roteiro + procedimentos

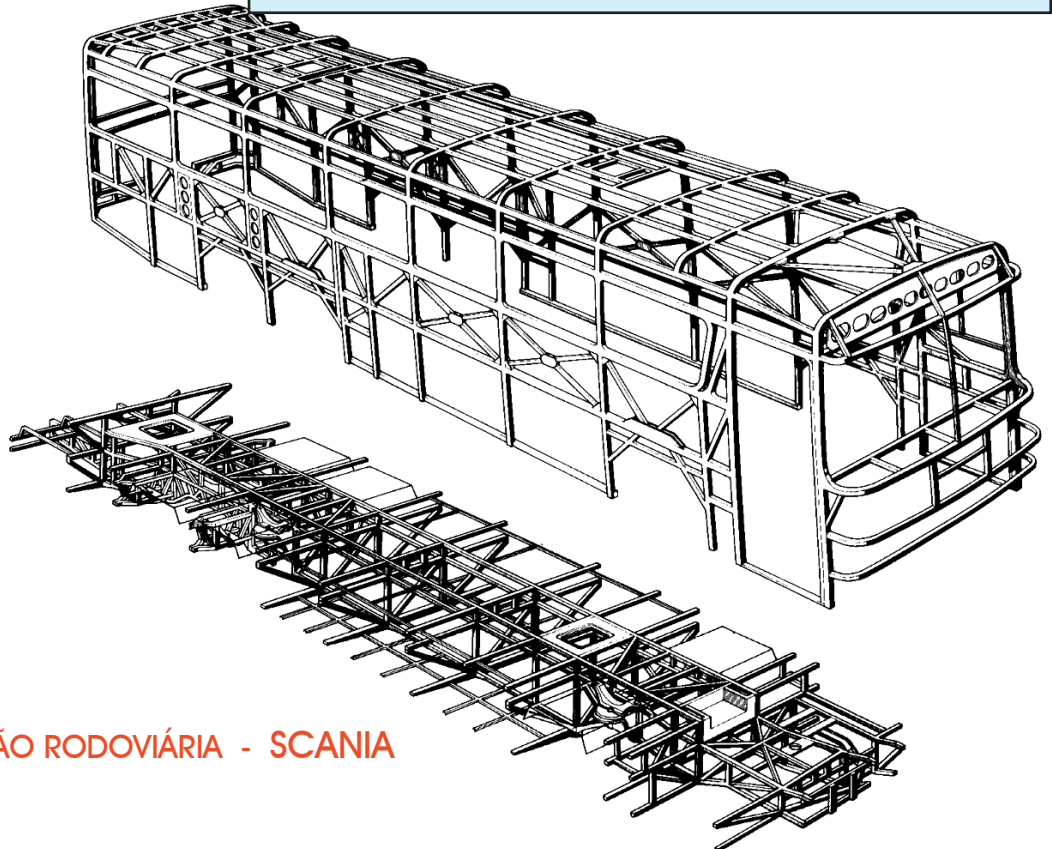

FROTA: OPERAÇÃO RODOVIÁRIA - SCANIA



astm

SIM - SISTEMA INTEGRADO DE MANUTENÇÃO

PMCC - PLANO DE MANUTENÇÃO CC (carroceria)

1) Principais Objetivos:

- => Avaliação anual (aproxim.) do estado geral da carroceria
- => Avaliação da evolução da corrosão
- => Acerto geral da carroceria, interna e externamente



2) Roteiro - Procedimentos

| | |
|--------------------------|--------|
| Tempo previsto: => Total | 8:00 h |
|--------------------------|--------|

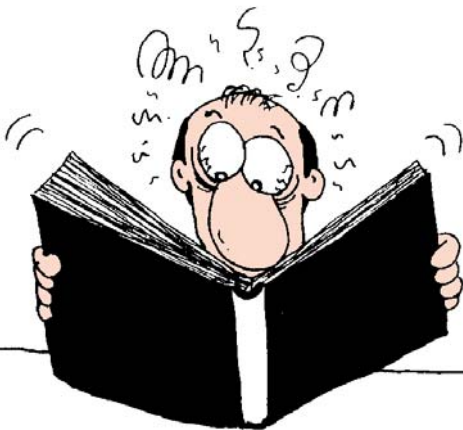

Obs.: => Plano efetuado em conjunto com o plano C ou D.

=> O estado geral da carroceria será determinante para o tempo total previsto.

=> Este plano é obrigatório em caso de reconstrução parcial após acidente.



astm

SIM - SISTEMA INTEGRADO DE MANUTENÇÃO

PMCC - PLANO DE MANUTENÇÃO CC (carroceria)

Ao vencer a quilometragem pré-determinada (programada):



3 - Considerar:



| | |
|-----------|--|
| RTM ⇒ | <ul style="list-style-type: none">- Reclamações do motorista- Anotações do revisador- Defeitos repetidos nos dias anteriores- Índice de Socorros + Retornos |
| FRC ⇒ | <ul style="list-style-type: none">- Avarias registradas |
| E ainda ⇒ | <ul style="list-style-type: none">- Avaliação do estado geral- Avaliação da progressão da corrosão- Seqüelas de acidentes anteriores |



astm

SIM - SISTEMA INTEGRADO DE MANUTENÇÃO

PMCC - PLANO DE MANUTENÇÃO CC (carroceria)

4 - Lavar



Chassis
+
Plataforma

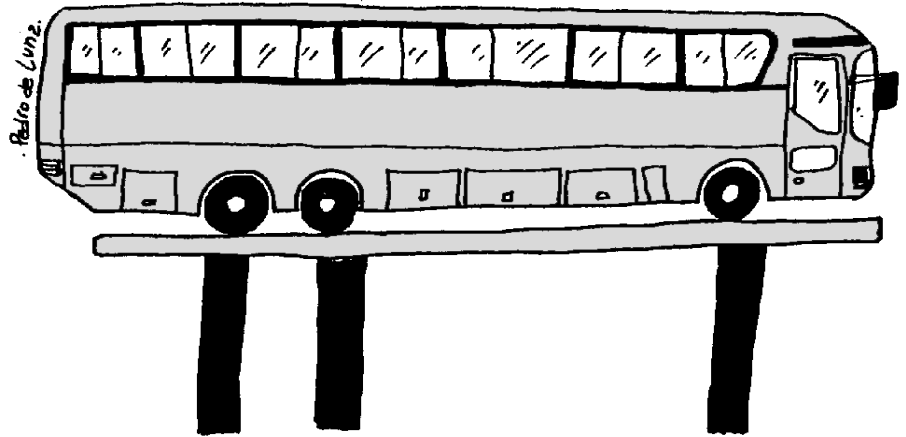

Lavar:



- => Interior veículo
- => Bagageiros
- => Compartimento motor
- => Carroceria



astm

SIM - SISTEMA INTEGRADO DE MANUTENÇÃO

PMCC - PLANO DE MANUTENÇÃO CC (carroceria)

5 - Estruturas internas:

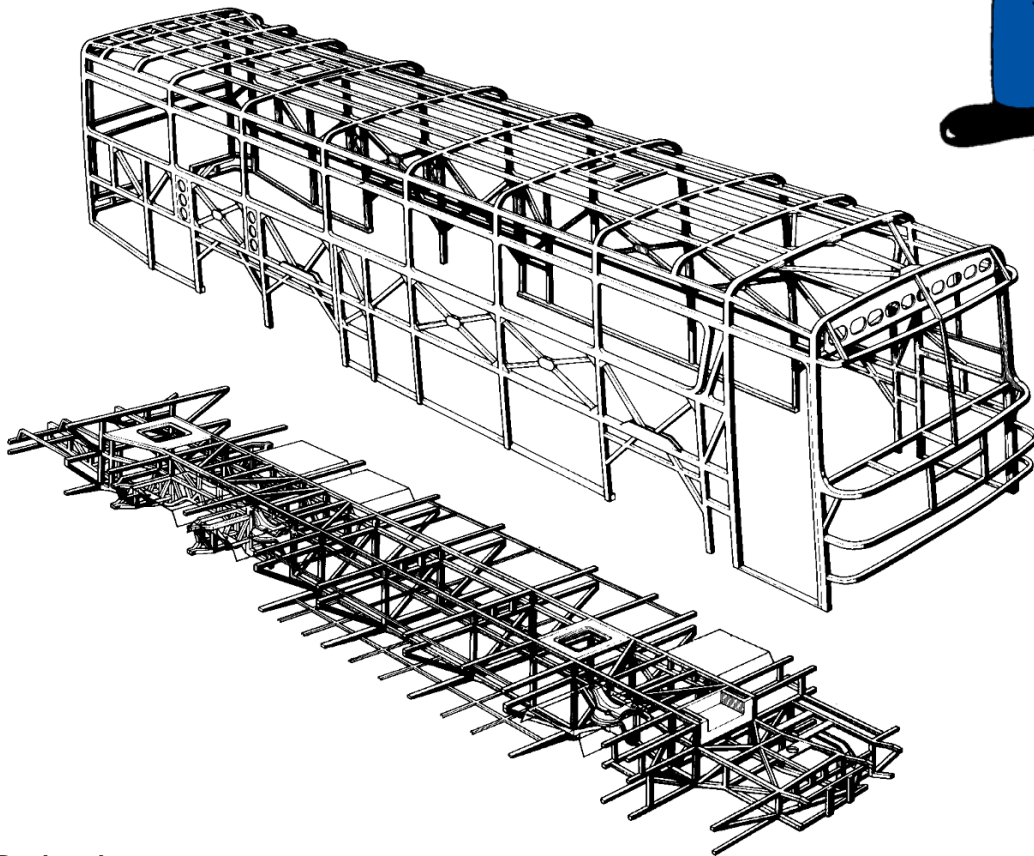

Detectar
trincas e
colunas (estruturas) quebra-



astm

SIM - SISTEMA INTEGRADO DE MANUTENÇÃO

PMCC - PLANO DE MANUTENÇÃO CC (carroceria)

6 - Lanternagem + pintura:

↓
Acertar

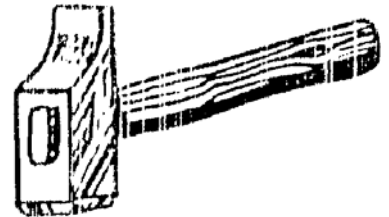
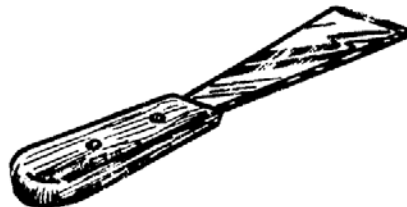
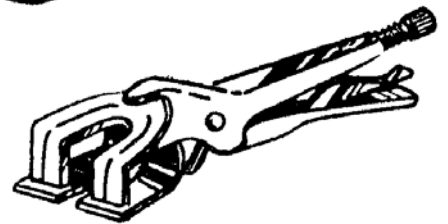
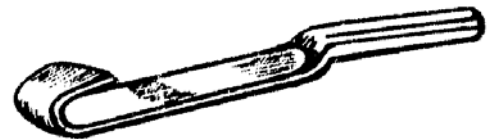
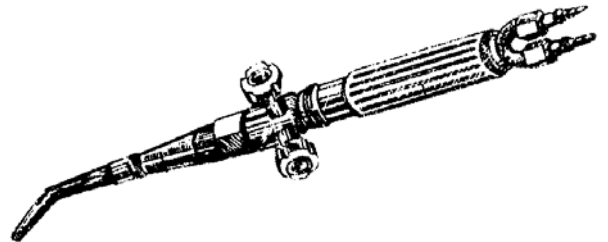
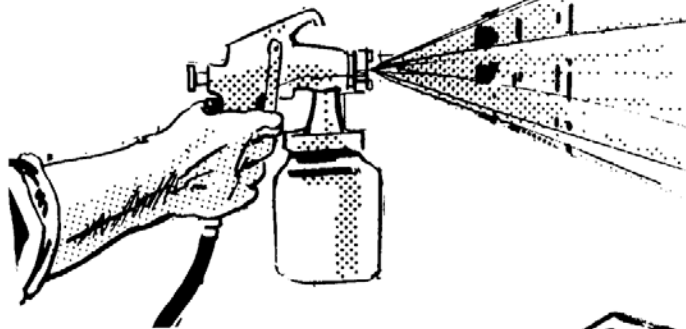
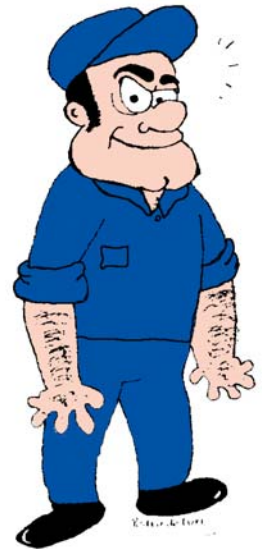
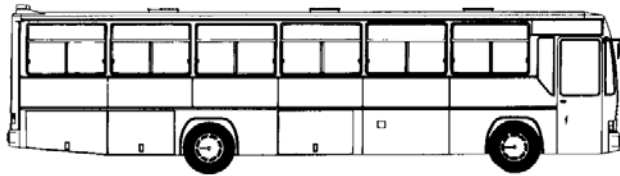



astm

SIM - SISTEMA INTEGRADO DE MANUTENÇÃO

PMCC - PLANO DE MANUTENÇÃO CC (carroceria)

7 - Borrachas + Vedações:



Substituir se necessário

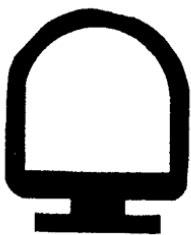
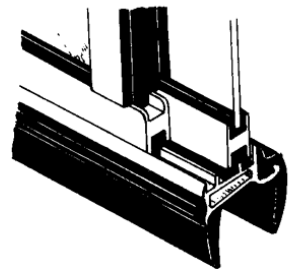
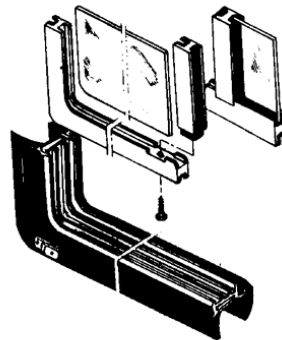
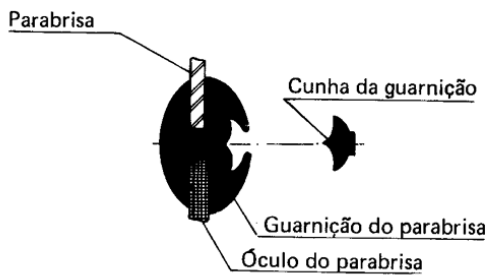
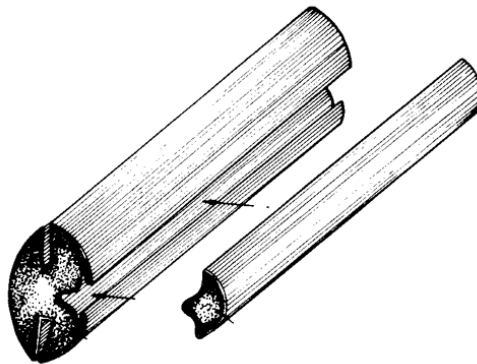
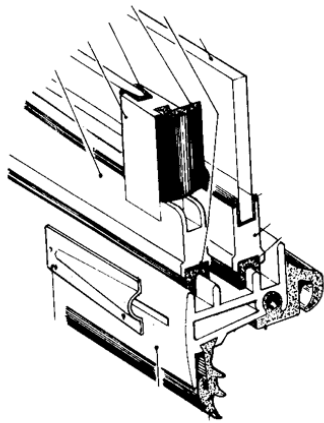



astm

SIM - SISTEMA INTEGRADO DE MANUTENÇÃO

PMCC - PLANO DE MANUTENÇÃO CC (carroceria)

8 - Borrachas + Vedações: (aplicação)

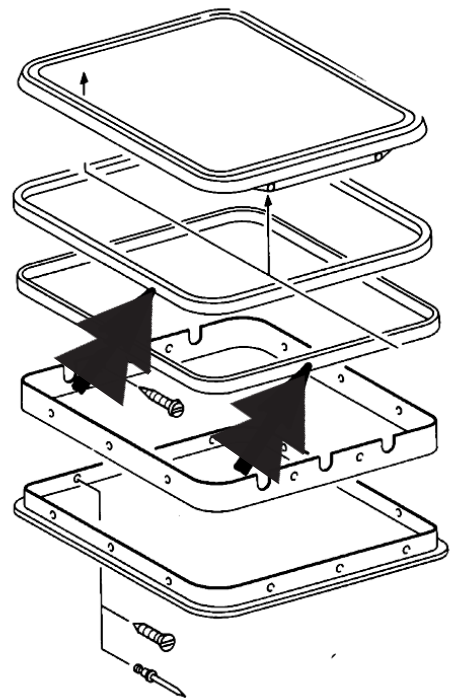
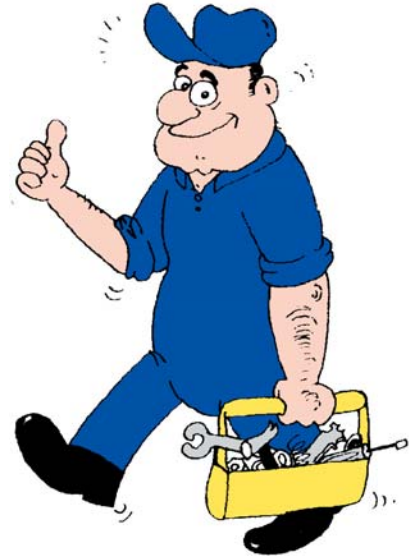
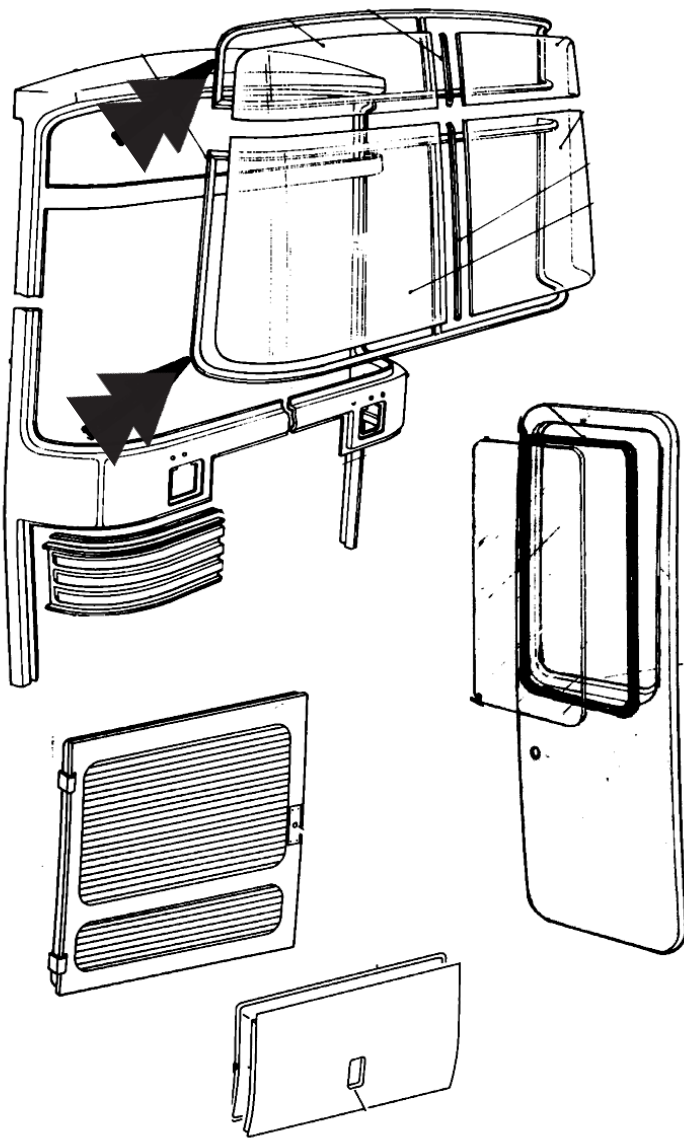



astm

SIM - SISTEMA INTEGRADO DE MANUTENÇÃO

PMCC - PLANO DE MANUTENÇÃO CC (carroceria)

9 - Portas de acesso:

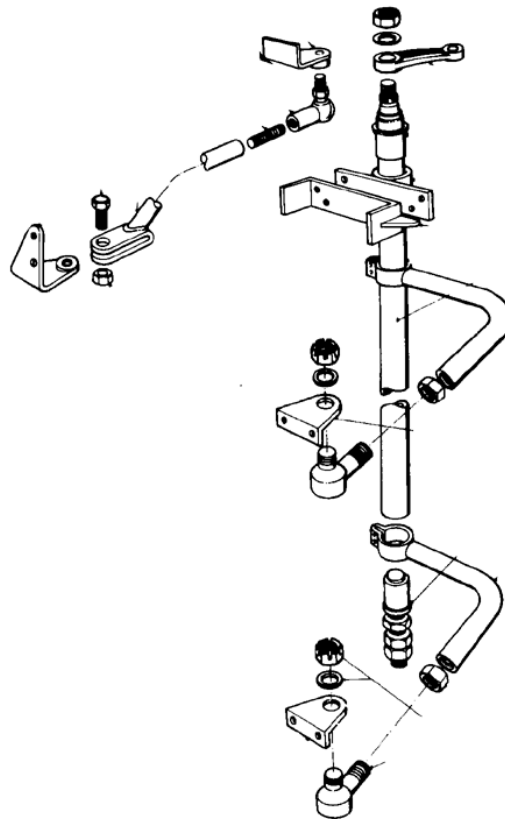
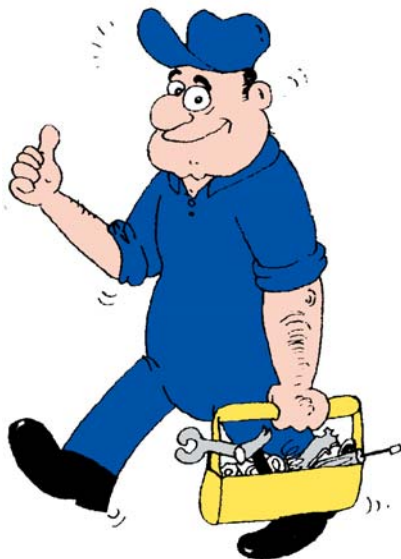
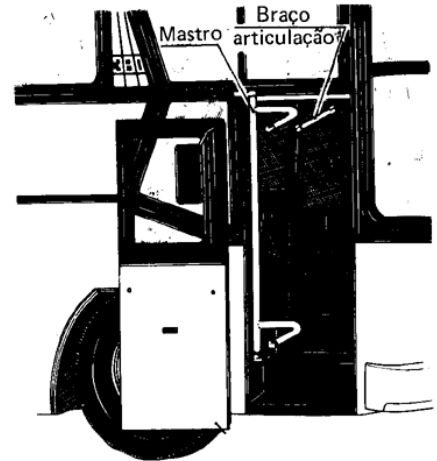
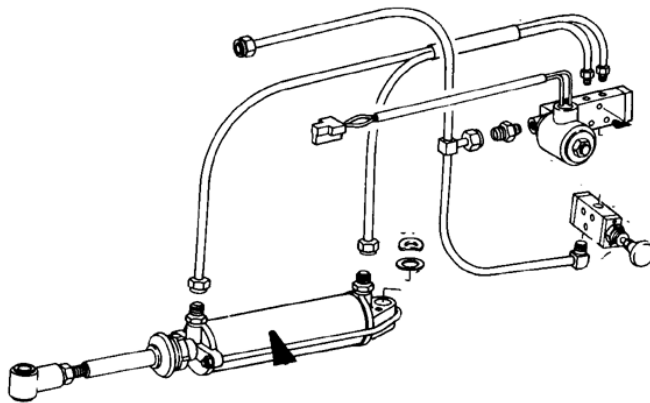



astm

SIM - SISTEMA INTEGRADO DE MANUTENÇÃO

PMCC - PLANO DE MANUTENÇÃO CC (carroceria)

10 - Tampas bagageiros + Motor:

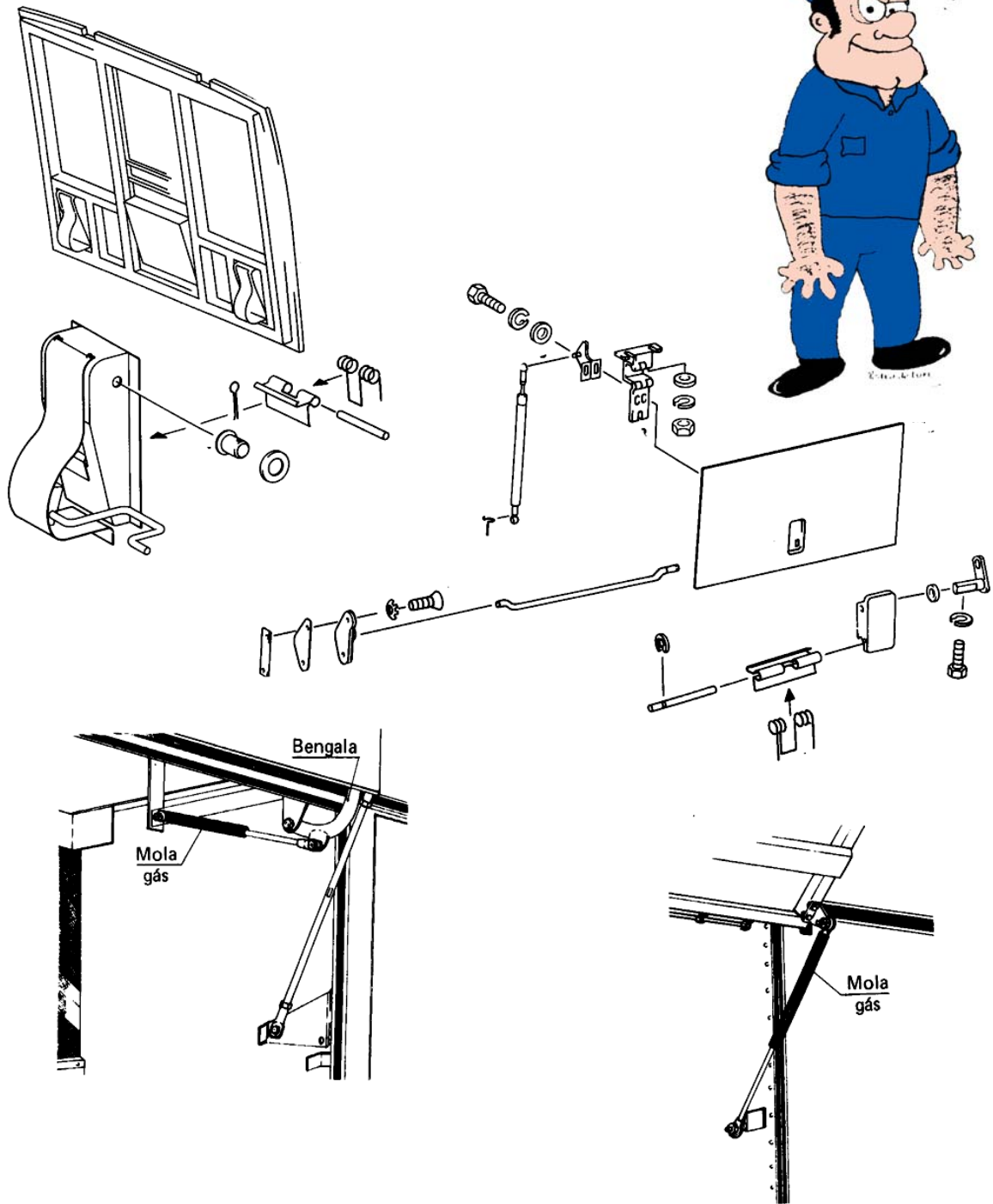

FROTA: OPERAÇÃO RODOVIÁRIA - SCANIA



astm

SIM - SISTEMA INTEGRADO DE MANUTENÇÃO

PMCC - PLANO DE MANUTENÇÃO CC (carroceria)

11 - Quebra -sol:

- Retrovisores internos + externos
- Itinerário (vista)

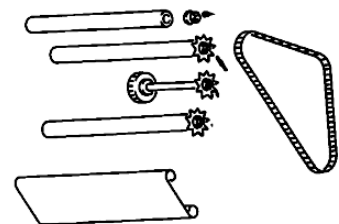
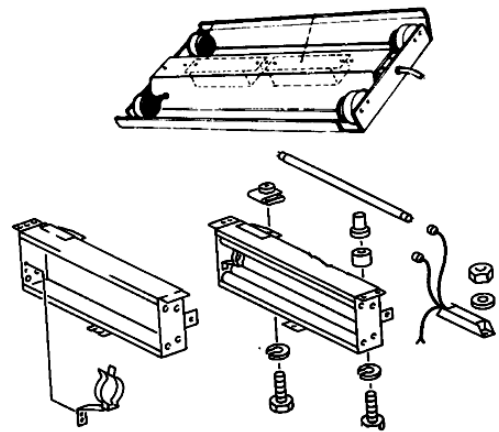
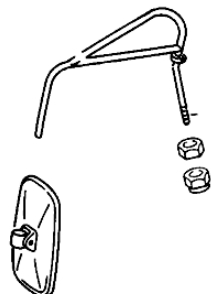
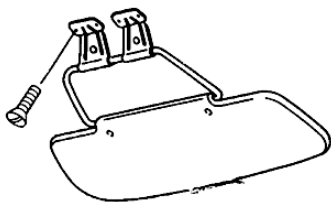
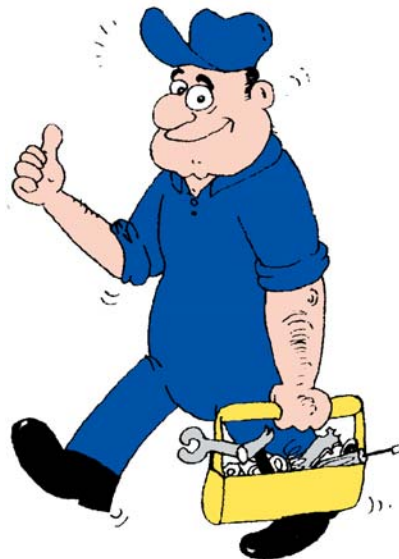

FROTA: OPERAÇÃO RODOVIÁRIA - SCANIA



astm

SIM - SISTEMA INTEGRADO DE MANUTENÇÃO

PMCC - PLANO DE MANUTENÇÃO CC (carroceria)

12 - Guicho para pneu estepe:

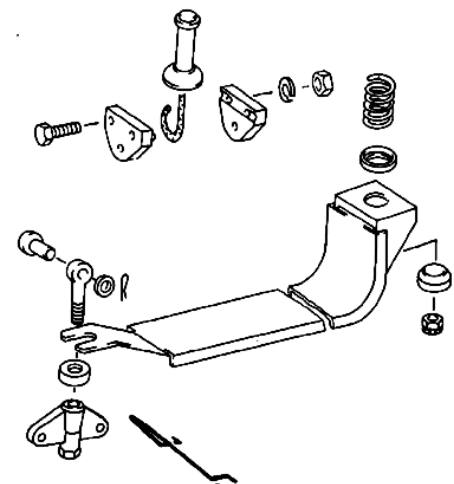
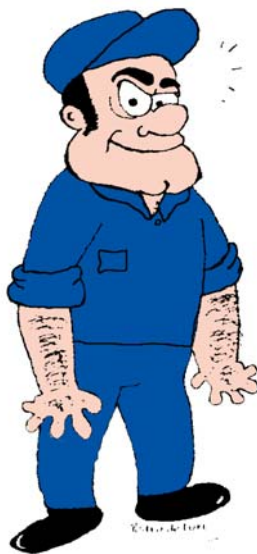
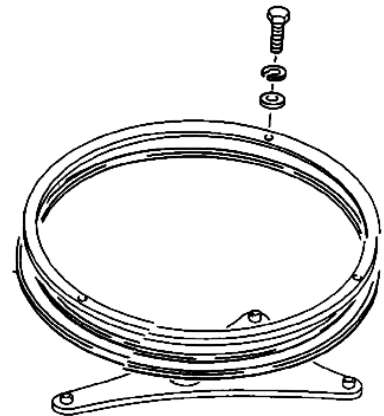
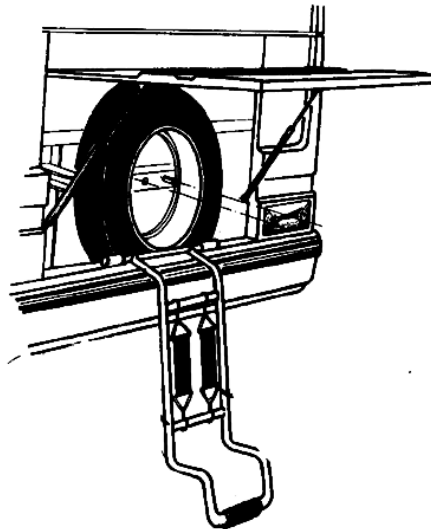
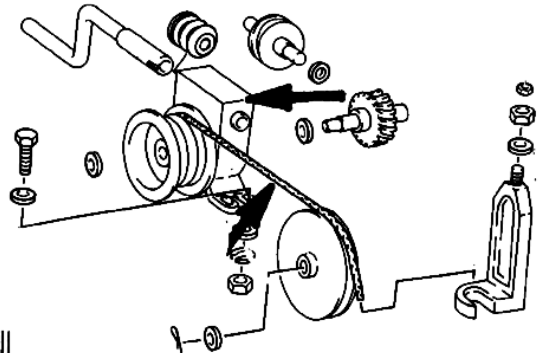
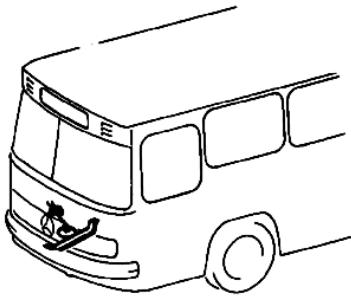

FROTA: OPERAÇÃO RODOVIÁRIA - SCANIA



astm

SIM - SISTEMA INTEGRADO DE MANUTENÇÃO

PMCC - PLANO DE MANUTENÇÃO CC (carroceria)

13 - Área de trabalho do motorista:

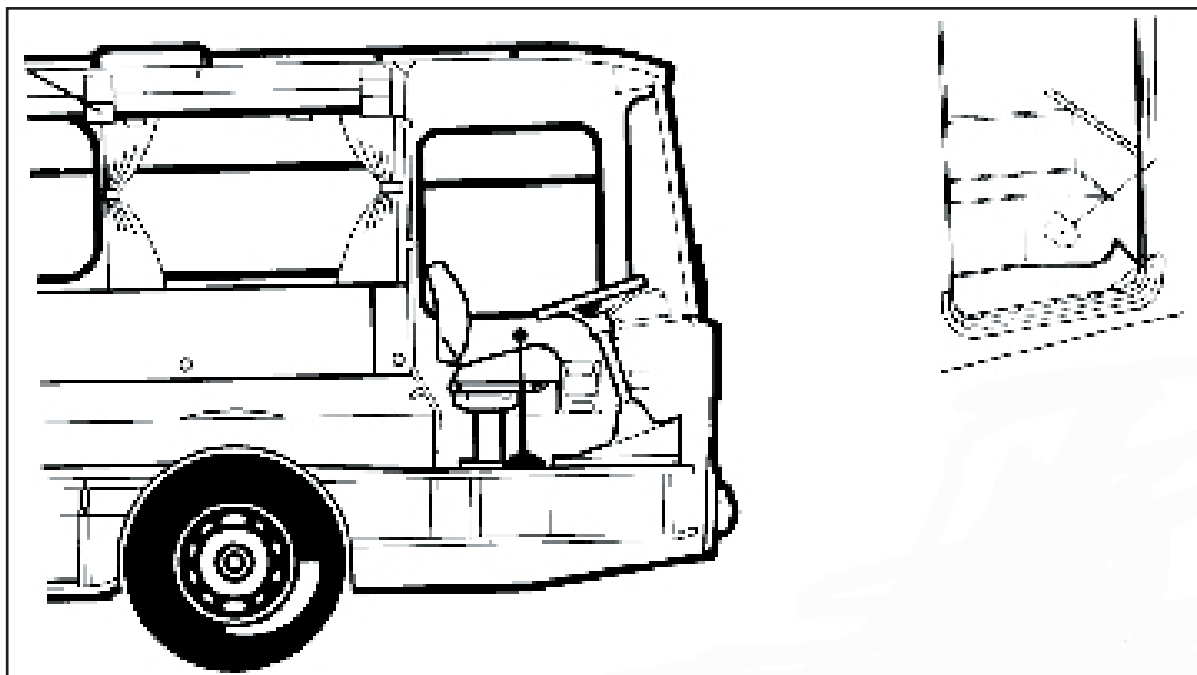

FROTA: OPERAÇÃO RODOVIÁRIA - SCANIA



astm

SIM - SISTEMA INTEGRADO DE MANUTENÇÃO

PMCC - PLANO DE MANUTENÇÃO CC (carroceria)

14 - Interior - Bancos:

- => Cinzeiros
- => Baracinho
- => Reclinável
- => Estofamen

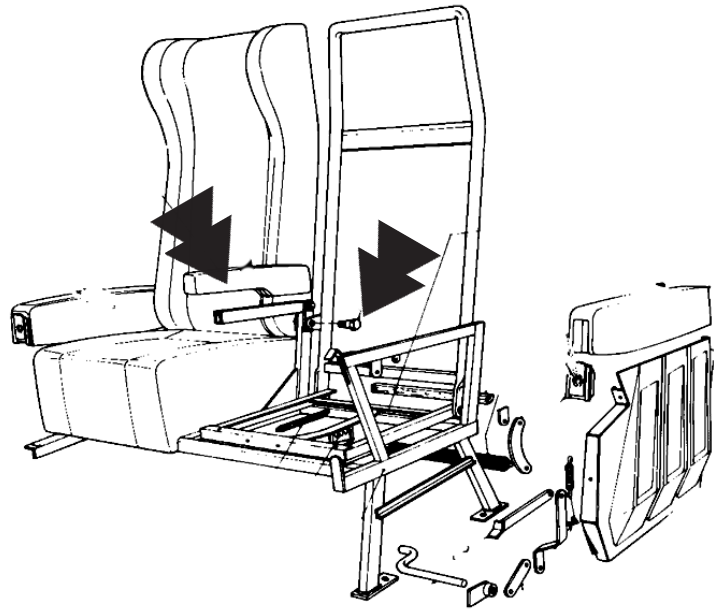

Pontos Críticos

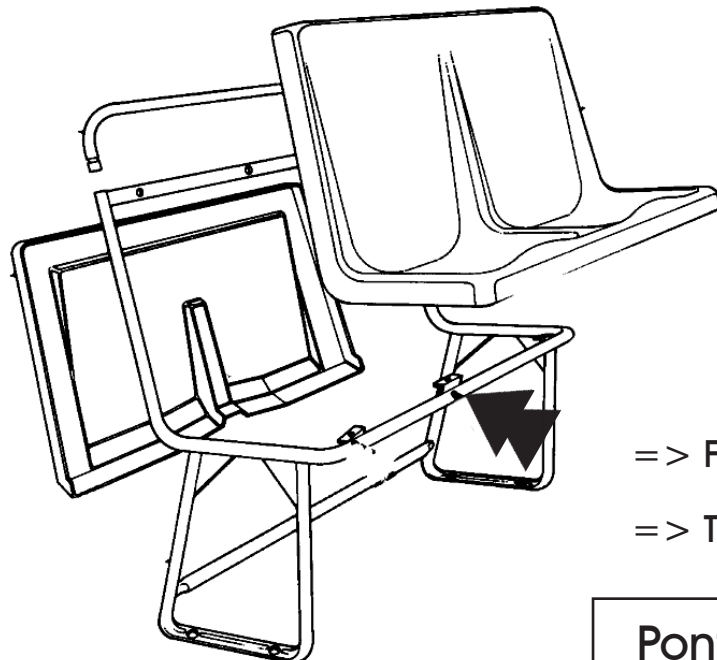
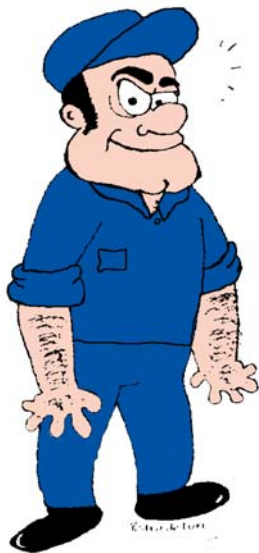

- => Fixação
- => Trincas

Pontos Críticos



astm

SIM - SISTEMA INTEGRADO DE MANUTENÇÃO

PMCC - PLANO DE MANUTENÇÃO CC (carroceria)

15 - Interior - Geral:

- => Estofamento
- => Porta-embrulhos
- => Teto
- => Assoalho
- => Bagageiro
- => Carpete
- => Cortinas

- Estado
- Visual
- Fixação

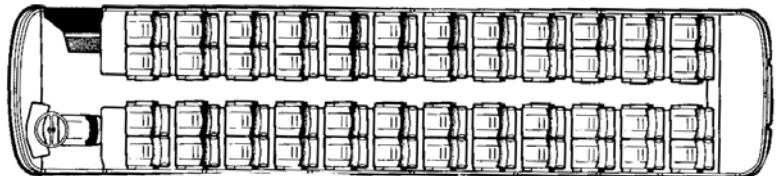
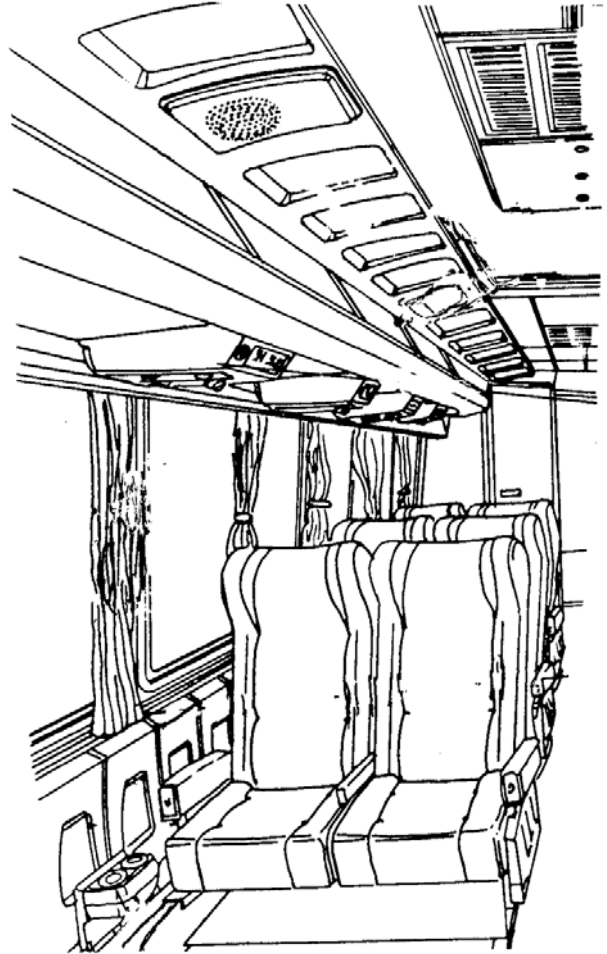

FROTA: OPERAÇÃO RODOVIÁRIA - SCANIA



astm

SIM - SISTEMA INTEGRADO DE MANUTENÇÃO

PMCC - PLANO DE MANUTENÇÃO CC (carroceria)

16 - Banheiro (Sanitário):

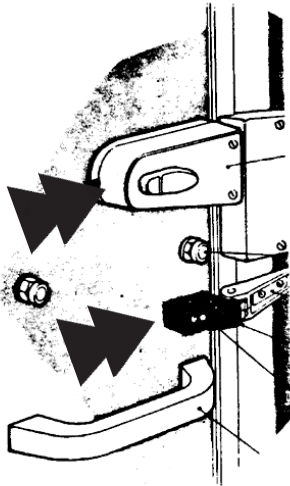
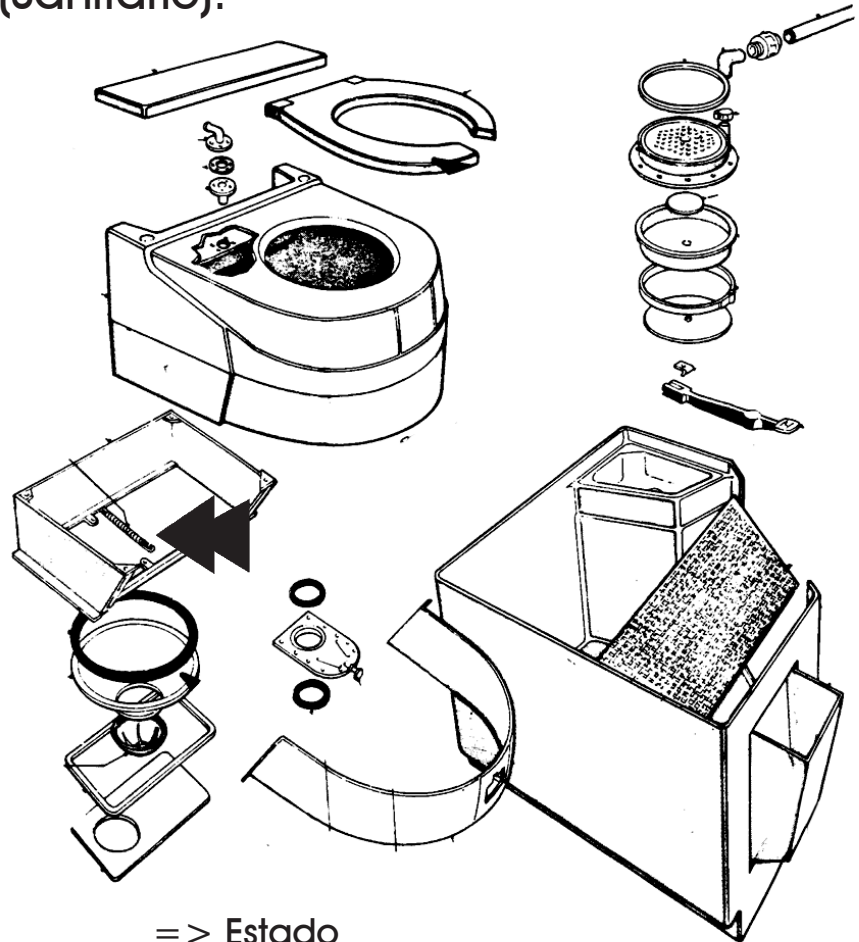

- => Estado
- => Fixação
- => Funcionamento
- => Vedações
- => Trincas

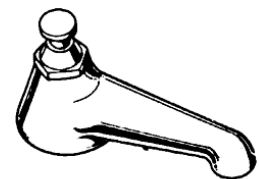

Tranca da porta



astm

SIM - SISTEMA INTEGRADO DE MANUTENÇÃO

PMCC - PLANO DE MANUTENÇÃO CC (carroceria)

17 - E ainda:

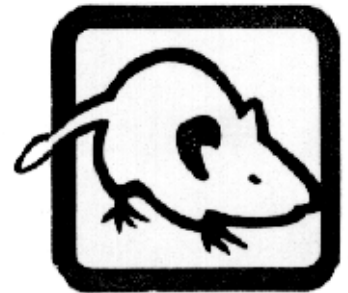
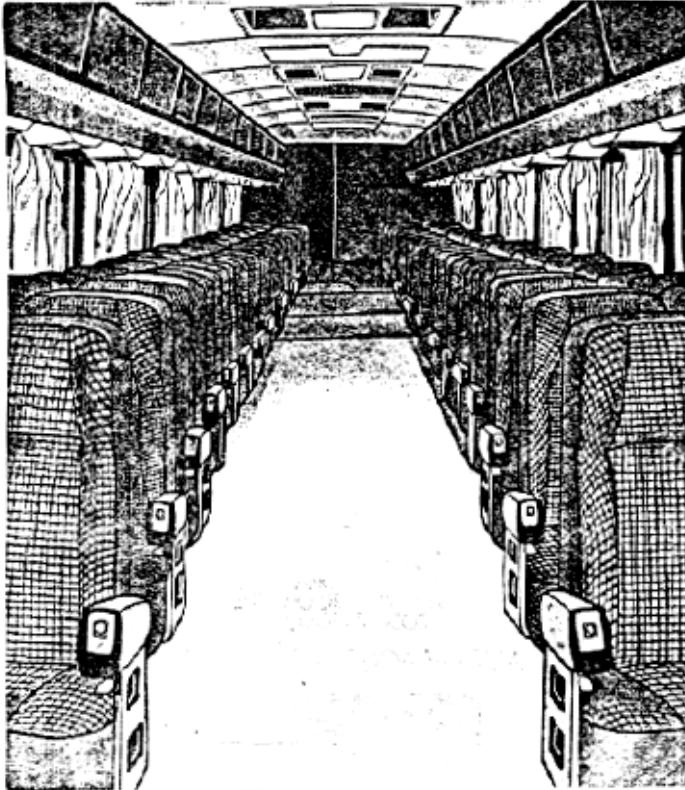

=> Lavagem Final

=> Higienização

=> Dedetização

Controle final de qualidade

FROTA: OPERAÇÃO RODOVIÁRIA - SCANIA